

◆ 10G-CWDM10-XXE

10Gbps SFP+ CWDM 10Km Transceiver

Product Feature

- Up to 11.3 Gb/s data links
- DFB laser transmitter and PIN photo-detector
- Up to 10km on 9/125µm SMF
- Hot-pluggable SFP+ footprint
- Dual/Duplex LC connector
- Low power dissipation
- Metal enclosure, for lower EMI with connector retainer
- RoHS compliant and lead-free
- Single +3.3V power supply
- Support Digital Diagnostic Monitoring interface
- Compliant with SFF-8431, SFF-8432, IEEE 802.3ae; SFF-8472
- Case operating temperature
Expand: -20°C to +85°C
Commercial: 0°C to +70°C



Applications

- 10GBASE-BX&10GBASE-BX/LW
- 10GSONET/SDH,OTU2/2e
- Other Optical Links

Product Description

10G-CWDM10-XX Small Form Factor Pluggable (SFP+) transceivers are compatible with the Small Form Factor Pluggable Multi-Sourcing Agreement (MSA). The transceiver consists of five sections: the LD driver, the limiting amplifier, the digital diagnostic monitor, the DFB laser and the PIN photo-detector. The module data link up to 10KM in 9/125 µm single mode fiber.

The optical output can be disabled by a TTL logic high-level input of Tx Disable, and the system also can disable the module via I2C. Tx Fault is provided to indicate that degradation of the laser. Loss of signal (LOS) output is provided to indicate the loss of an input optical signal of receiver or the link status with partner. The system can also get the LOS (or Link)/Disable/Fault information via I2C register access.

Product Selection

Part Number	Operating Case temperature	DDMI
	Commercial (0~70°C)	Yes

Product part Number	Data Rate (Gbps)	Media	Wavelength (nm)	Transmission Distance(km)	Clasp Color Code
10G-CWDM10-27E	10.3125	Single mode fiber	1271	10	Aqua blue
10G-CWDM10-29E	10.3125	Single mode fiber	1291	10	Peach
10G-CWDM10-31E	10.3125	Single mode fiber	1311	10	Olive
10G-CWDM10-33E	10.3125	Single mode fiber	1331	10	Kelly
10G-CWDM10-35E	10.3125	Single mode fiber	1351	10	Sky Blue
10G-CWDM10-37E	10.3125	Single mode fiber	1371	10	Pink
10G-CWDM10-39E	10.3125	Single mode fiber	1391	10	Gray
10G-CWDM10-41E	10.3125	Single mode fiber	1411	10	Gray
10G-CWDM10-43E	10.3125	Single mode fiber	1431	10	Gray
10G-CWDM10-45E	10.3125	Single mode fiber	1451	10	Blue
10G-CWDM10-47E	10.3125	Single mode fiber	1471	10	Gray
10G-CWDM10-49E	10.3125	Single mode fiber	1491	10	Purple
10G-CWDM10-51E	10.3125	Single mode fiber	1511	10	Blue
10G-CWDM10-53E	10.3125	Single mode fiber	1531	10	Green
10G-CWDM10-55E	10.3125	Single mode fiber	1551	10	Yellow
10G-CWDM10-57E	10.3125	Single mode fiber	1571	10	Orange
10G-CWDM10-59E	10.3125	Single mode fiber	1591	10	Red
10G-CWDM10-61E	10.3125	Single mode fiber	1611	10	Red

Pin Descriptions

Pin	Symbol	Name/Description	NOTE
1	VEET	Transmitter Ground (Common with Receiver Ground)	1
2	TFAULT	Transmitter Fault.	
3	TDIS	Transmitter Disable. Laser output disabled on high or open.	2
4	SDA	2 wire ID interface,SDA	3
5	SCL	2 wire ID interface,SCL	3
6	MOD_DEF(0)	Module Definition 0. Grounded within the module.	3
7	RS0	No connection required	4
8	LOS	Loss of Signal indication. Logic 0 indicates normal operation.	5
9	RS1	Receiver Ground (Common with Transmitter Ground)	1
10	VEER	Receiver Ground (Common with Transmitter Ground)	1
11	VEER	Receiver Ground (Common with Transmitter Ground)	1
12	RD-	Receiver Inverted DATA out. AC Coupled	
13	RD+	Receiver Non-inverted DATA out. AC Coupled	
14	VEER	Receiver Ground (Common with Transmitter Ground)	1
15	VCCR	Receiver Power Supply	
16	VCCT	Transmitter Power Supply	
17	VEET	Transmitter Ground (Common with Receiver Ground)	1
18	TD+	Transmitter Non-Inverted DATA in. AC Coupled.	
19	TD-	Transmitter Inverted DATA in. AC Coupled.	
20	VEET	Transmitter Ground (Common with Receiver Ground)	1

Notes:

1. Circuit ground is internally isolated from chassis ground.
2. Laser output disabled on $T_{DIS} > 2.0V$ or open, enabled on $T_{DIS} < 0.8V$.
3. Should be pulled up with 4.7k - 10kohms on host board to a voltage between 2.0V and 3.6V. MOD_DEF (0) pulls line low to indicate module is plugged in.
4. This is an optional input used to control the receiver bandwidth for compatibility with multiple data rates (most likely Fiber Channel 1x and 2x Rates). If implemented, the input will be internally pulled down with > 30kΩ resistor. The input states are:
 - Low (0 – 0.8V): Reduced Bandwidth
 - (>0.8, < 2.0V): Undefined
 - High (2.0 – 3.465V): Full Bandwidth
 - Open: Reduced Bandwidth
5. LOS is open collector output should be pulled up with 4.7k - 10kohms on host board to a voltage between 2.0V and 3.6V. Logic 0 indicates normal operation; logic 1 indicates loss of signal.

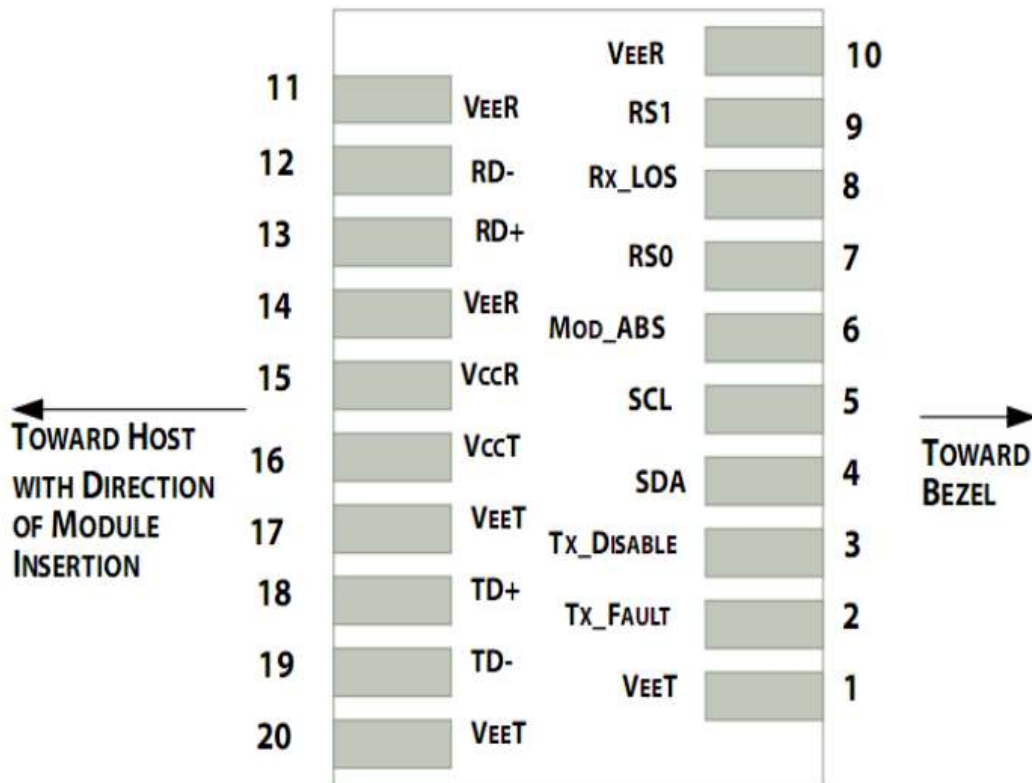

Pin-out of Connector Block on Host Board

Absolute Maximum Ratings

Parameter	Symbol	Min.	Typ.	Max.	Unit	Note
Storage Temperature	Ts	-50		+95	°C	
Relative Humidity	RH	0		95	%	
Power Supply Voltage	VCC	-0.5		+4	V	

Recommended Operating Conditions

Parameter	Symbol	Min.	Typ.	Max.	Unit	Note
Case Operating Temperature	TE	0		70	°C	Commercial
Power Supply Voltage	VCC	3.135	3.3	3.465	V	
Power Supply Current	ICC			350	mA	
Power Consumption	P			1.5	W	
Data Rate	BR	9.95	10.31	11.3	Gbps	
9/125 μm G.652 SMF	Lmax			10	km	

Electrical Characteristics

Parameter	Symbol	Min.	Typ.	Max.	Unit	Note
Transmitter						
Tx Disable Input-High	VDISH	2		Vcc+0.3	V	
Tx Disable Input-Low	VDISL	0		0.8	V	
Tx Fault Input-High	VTxFH	2		Vcc+0.3	V	
Tx Fault Input-Low	VTxFL	0		0.8	V	
Receiver						
LOSS -High	V _{LOSH}	2		Vcc+0.3	V	
LOSS -Low	V _{LOSL}	0		0.8	V	

Optical Characteristics

Parameter	Symbol	Min.	Typ.	Max.	Unit	Note
Transmitter						
Average Output Power	POUT	0		5	dBm	
Transmitter OFF Output Power	Poff			-45	dBm	
Center Wavelength	λ	$\lambda - 6.5$		$\lambda + 6.5$	nm	DFB Laser
Side mode suppression ratio	SMSR			30	dB	
Spectrum Bandwidth(-20dB)	σ			1	dB	
Extinction Ratio	ER	3.5			dB	
Receiver						
Receiver Sensitivity	SENS			-15	dBm	1
Receiver Overload		0.5			dBm	
Input Optical Wavelength	λ_C	1260		1620	nm	PIN-TIA
LOS De-assert	LOSD			-17	dBm	
LOS Assert	LOSA	-30			dBm	2
LOS Hysteresis		0.5			dB	

Note:

1. Measured with PRBS=2³¹-1 at BER = 10⁻¹²@10.3125Gbps
2. When LOS de-asserted, the RX data+/- output is High-level (fixed).

EEPROM Information

EEPROM memory map specific data field description is as below:

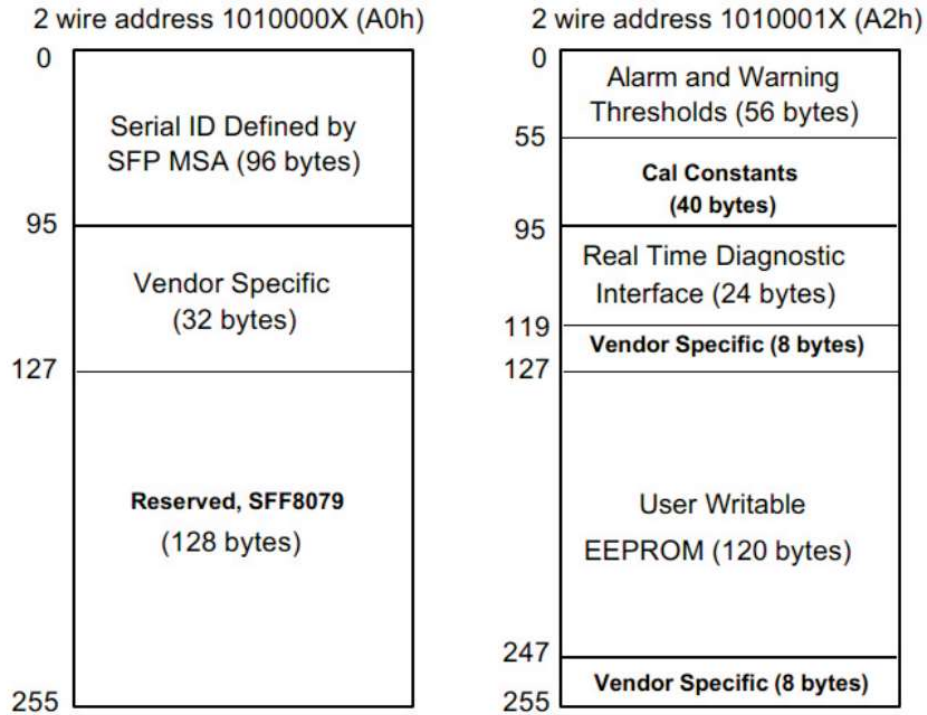

Digital Diagnostic Monitoring Interface

Five transceiver parameter values are monitored. The following table defines the monitored parameter's accuracy.

Parameter	Range	Accuracy	Calibration
Temperature	-20 to +85°C (E)	±3°C	Internal
	0 to +70°C (C)	±3°C	Internal
Voltage	2.97 to 3.63V	±3%	Internal
Bias Current	0 to 100mA	±10%	Internal
TX Power	-4 to 3 dBm or 0 to 8dBm	±3dBm	Internal
RX Power	-15 to 1 dBm	±3dBm	Internal

Recommend Circuit Schematic

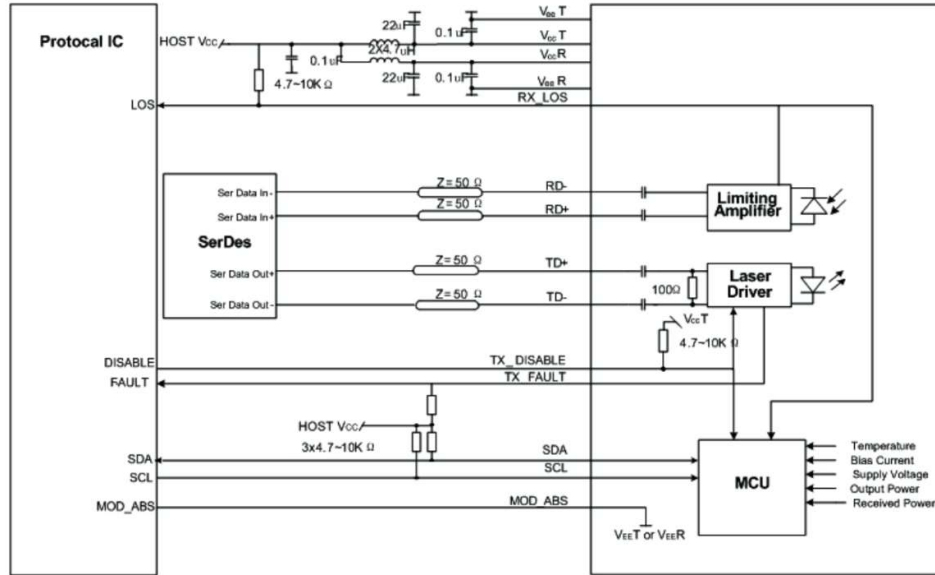

Mechanical Specifications

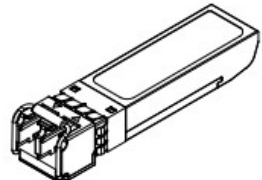
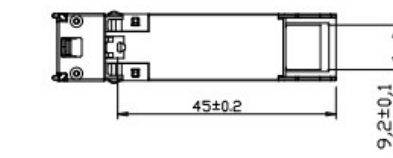
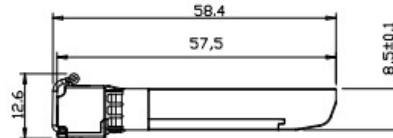

Units in mm

Revision History

Revision	Initiated	Reviewed	Approved	DCN	Release Date
Version1.0	Zhangchengxing	pengyanhui	Liubin	New Released.	July 28, 2017
Version1.1	Zhangchengxing	pengyanhui	Liubin	Updated document	Dec 10,2020